

**FSX DPF CLEANING EQUIPMENT
-BASE PACKAGE FLOOR
LAYOUT-NOVEMBER 2010**

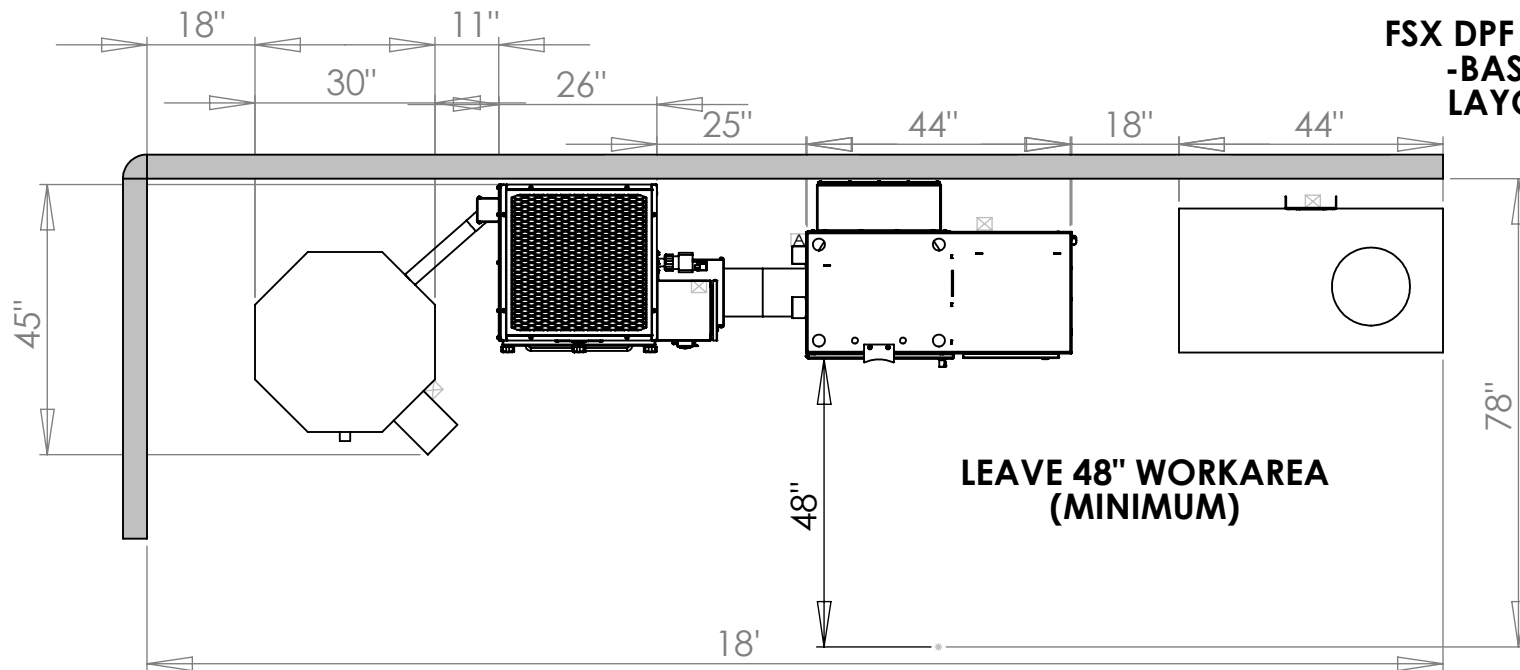

**LEAVE 48" WORKAREA
(MINIMUM)**

FROM WALL WITH
1" CLEARANCE BEHIND
SOOTSUCKER 2 AND
TRAPBLASTER 7.

- A AIR CONNECTION
POINT-1" NPT
- X ELECTRICAL CONNECTION

- TRAP BURNER 7 (6' LEAD)
FROM THIS POINT.
- SOOTSUCKER 2, TRAP BLASTER 7,
TRAP TESTER 7 (10' LEADS)
FROM THIS POINT.

